

# DUAL SPACING OF WHEELS

As shown in the diagram below, the sum of the wheel offsets of the two wheels used equals the dual spacing. The recommended minimum dual spacing for tire clearance is shown in the chart to the right.

Tire clearance can be calculated by subtracting one tire section width from the sum of the two wheel offsets. This information is found in tire data books (also see chart). For more accuracy, the grown tire width at the rated load can be used instead of the new tire section width. This dimension can be obtained either by actual measurement of the tire width (including protective side ribs) or by referring to the tire manufacturer's data book.

In addition to determining tire clearance, the wheel offset directly affects two other important dimensions: (1) the vehicle clearance and (2) the overall vehicle width of tires (see diagram below).

Vehicle body clearance, which is the distance from the inside tire to the spring or other body structures, will change proportionally to any change in offset of the inside wheel.

The overall vehicle width of tires is the distance from the outside tire wall of one tire to the outside tire wall of the tire on the opposite end of the axle. This dimension will be altered correspondingly by an increase or decrease in wheel offset. Overall vehicle width will change proportionally to any offset changes of the wheel, if the tire projects beyond the body structure. The maximum vehicle width is regulated by law.

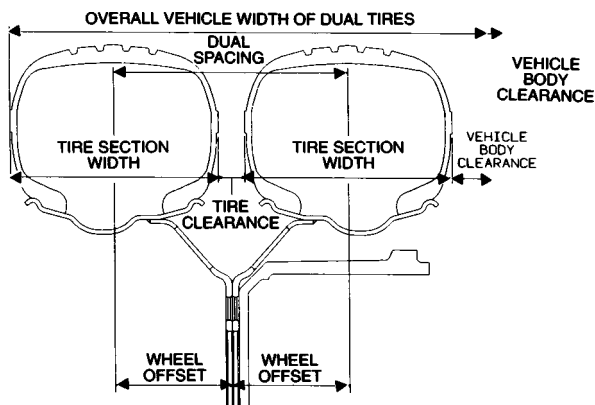

<b>Wheel Selection And Tire Spacing</b>			
Information from The Tire & Rim Association 1996 Yearbook			
Tire Sizes <sup>(1)</sup>	Design Rim Width <sup>(2)</sup>	Tire Section Width <sup>(3)</sup>	Minimum Dual Spacing <sup>(3)</sup>
<b>Light Truck</b>			
7.50★16LT	6.00	8.65	10.00
LT225/75★16	6.00	8.75	10.20
LT245/75★16	7.00	9.76	11.34
LT265/75★16	7.50	10.51	12.20
LT285/75★16	8.00	11.26	13.07
LT215/85★16	6.00	8.50	9.88
LT235/85★16	6.50	9.25	10.75
LT255/85★16	7.00	10.04	11.65
8.00★16.5	6.00	8.00	9.00
8.75★16.5	6.75	8.75	9.90
9.50H16.5	6.75	9.50	10.70
<b>Medium And Heavy Truck</b>			
7.50★15TR, 20	6.00	8.45	9.70
8.25★15TR, 20	6.50	9.30	10.60
9.00★15TR, 20	7.00	10.20	11.70
10.00★15TR, 20, 22	7.50	10.95	12.50
11.00★15TR, 20, 22, 24	8.00	11.55	13.00
12.00★20, 24	8.50	12.40	14.20
13.00★20	9.00	13.40	16.20
14.00★20, 24	10.00	14.75	17.70
8★17.5HC, 19.5, 22.5	6.00	8.00	9.20
225/70★19.5	6.75	8.90	10.00
9★17.5HC, 22.5	6.75	9.00	10.30
245/70★19.5	7.50	9.76	10.98
245/75★22.5	7.50	9.76	10.98
255/70★22.5	7.50	10.04	11.30
10★17.5HC, 22.5	7.50	10.00	11.40
265/70★19.5	7.50	10.31	11.61
265/75★22.5	7.50	10.31	11.61
11★17.5HC, 22.5, 24.5	8.25	11.00	12.60
285/75★24.5	8.25	11.14	12.52
295/75★22.5	9.00	11.73	13.19
305/70★19.5	9.00	12.01	13.50
305/75★22.5	9.00	12.01	13.50
12★22.5, 24.5	9.00	11.80	13.50
12.5★22.5	9.00	11.90	13.60
12.75★22.5	9.00	12.27	13.60
315/80R22.5	9.00	12.28	13.82

<sup>(1)</sup>A ★ denotes both radial and bias tires.

<sup>(2)</sup>For additional approved rim contours and widths see page 50.

<sup>(3)</sup>Tire section width and minimum dual spacings will change 0.1" for each 1/4" change in rim width from the design rim width.